

705 SCIF DOOR & LOCK PACKAGE: RF 40 dB, STC-50 HYBRID, S&G LEVER/LEVER

- STC-50 lab rated performance per ASTM E90, which meets ICD 705 SCIF criteria for sound groups 3 & 4.

- Radio Frequency (RF) SE 40 db performance. Attenuates electric field, plane wave and microwave frequencies from 1 KHz through 18 GHz, lab tested per IEEE-299.

- Krieger HC30 cam-lift hinges are 100% ADA compliant on door leaves which weigh up to 700 lbs. Hinges can be ordered with optional security pins to enhance the openings security.

- Can be UL10C smoke rated up to 20-minutes.

- Single hybrid seal system simplifies installation and adjustment, while maintaining durability.

- 14 Gauge Stainless Steel (SS) frame comes standard with a 1/4" thick factory welded SS non-directional finish threshold.

- 2 piece slip-in frame comes standard for existing wall applications and simplifies installation.

(6 5/8" Jamb w/ 1/8" Removable Trim - Net Jamb Depth 6 3/4")

- 14 Gauge door skins come standard.

- Insulated door panel comes standard.

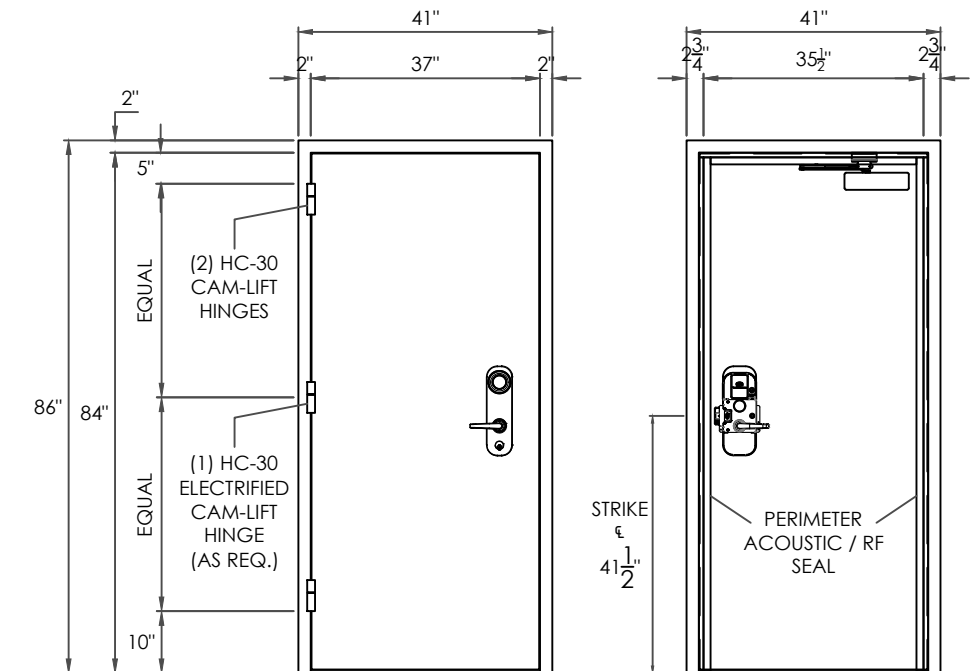

VIEW FROM PULL SIDE

VIEW FROM PUSH SIDE

INSIDE ROOM, OR SECURE SIDE.

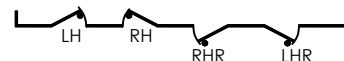

OUTSIDE, CORRIDOR, OR NON-SECURE SIDE.

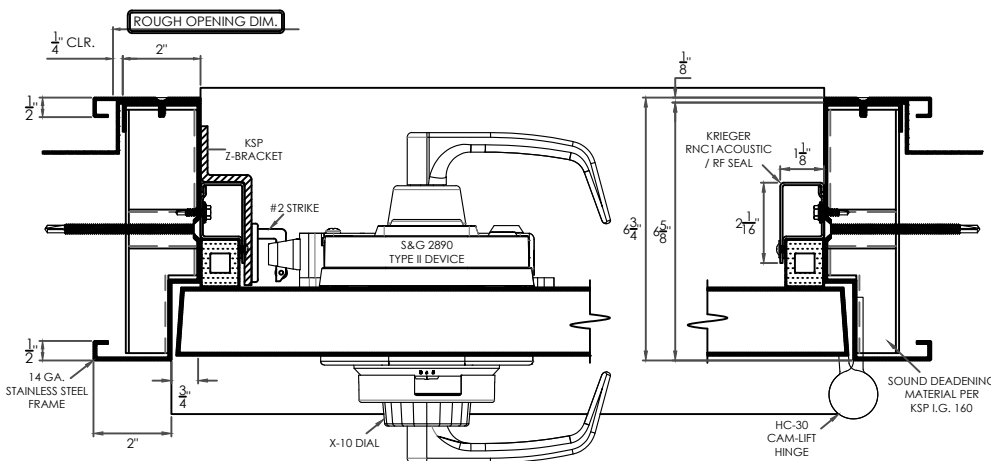

HORIZONTAL SECTION

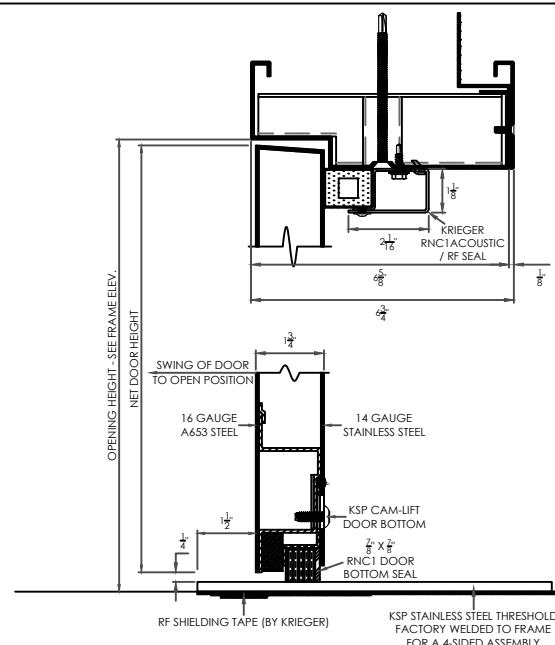

VERTICAL SECTION