



GUIDE SPECIFICATIONS FOR
FORCED ENTRY / BULLET
RESISTANT (FE/BR)
SECURITY HOLLOW METAL
DOORS AND FRAMES



This standard was developed by representative members of the Hollow Metal Manufacturers Association Division (HMMA) of the National Association of Architectural Metal Manufacturers (NAAMM) to provide their opinion and guidance on the specification and use of FE/BR security hollow metal doors and frames. This standard contains advisory information only and is published as a public service by NAAMM and its HMMA Division. NAAMM and its HMMA Division disclaim all liability of any kind for the use, application, or adaptation of material published in this standard.

Purchasers of NAAMM Standards can receive current information on all NAAMM Standards by calling, writing, or visiting the website of the National Association of Architectural Metal Manufacturers at www.naamm.org.

National Association of Architectural Metal Manufacturers

800 Roosevelt Road

Bldg. C, Suite 312

Glen Ellyn, Illinois 60137

Phone: (630) 942-6591 Fax: (630) 790-3095 www.naamm.org

Copyright © 2021

National Association of Architectural Metal Manufacturers

All Rights Reserved

TABLE OF CONTENTS

Introduction.....	ii
Foreword	iii
Part 1 – GENERAL	
1.01 Summary.....	1
1.02 Products Provided Under This Section.....	1
1.03 Related Sections.....	1
1.04 References	2
1.05 Testing and Performance	3
1.06 Quality Assurance	5
1.07 Submittals	6
Part 2 – PRODUCTS	
2.01 Steel	6
2.02 FE/BR Security Hollow Metal Doors	7
2.03 FE/BR Security Hollow Metal Panels	9
2.04 FE/BR Security Hollow Metal Frames	9
2.05 Manufacturing Tolerances	12
2.06 Hardware Locations.....	13
2.07 Finish.....	14
Part 3 – EXECUTION	
3.01 Site Storage and Protection of Materials	14
3.02 Installation	14
3.03 Clearances.....	16
Tables	4, A4, A5
APPENDIX (Not part of the Standard)	
X1. Guidelines for Use	A1
Figures	A8
Steel Tables NAAMM/HMMA – 803.....	A12

INTRODUCTION

FE/BR SECURITY HOLLOW METAL SYSTEMS

For many years, hollow metal door and framing systems have been used as the primary and initial defense against forced entry. Architects, specifiers, and end users have come to understand the advantages of using hollow metal doors and frames in FE/BR, “Forced Entry / Bullet Resistant”, security applications, such as, airports, convention centers, hotels, and offices, and in foreign and domestic government buildings such as, embassies, offices, and barracks.

The original standard, ANSI/NAAMM HMMA 862-03, was developed to provide guidance in the specification of FE/BR security hollow metal doors and frames where protection from vandalism, forced entry, theft, and firearms attack is a paramount concern.

It is necessary when writing a FE/BR security specification to keep in mind the security aspects of the entire opening – door, frame, hardware, glazing and wall construction. The test performance criteria set forth in this document simulates the “total opening” and its ability to frustrate forced entry, and ballistic penetration.

DESIGN VERSATILITY

FE/BR hollow metal construction provides the architect with a great deal of freedom in the design of hollow metal products. The architect can also take advantage of the expertise acquired by those hollow metal manufacturers experienced in FE/BR security work. Over the years NAAMM/HMMA manufacturers have developed advanced methods and equipment enabling them to efficiently manufacture hollow metal assemblies, which address today’s difficult FE/BR security applications. These applications include working with the latest in burglary and bullet resisting hardware and security glazing. A number of these manufacturers offer proven economical and functional designs of FE/BR security hollow metal systems.

EVALUATING FORCED ENTRY / BULLET RESISTANT (FE/BR) SECURITY HOLLOW METAL SYSTEMS

In order to evaluate the performance of FE/BR security hollow metal, it has been necessary to develop testing methods which simulate in the laboratory the system’s ability to frustrate attacks initiated by unskilled, semi-skilled and skilled assailants and/or the system’s ability to resist ballistic penetrations. One objective of this development work is to provide a standardized means of measuring performance which architects can call for in their specifications. Another objective is to provide manufacturers standardized means of testing and inspecting their products, improving their designs, and maintaining high quality construction. Finally, maintenance of rigorous standards and methods of testing construction and performance gives assurance of protection to the end user and the public in general. The performance requirement and methods of testing set forth in this voluntary standard will go a long way towards realizing the stated objectives.

TESTING

This standard for FE/BR security hollow metal has been developed to allow architects to specify doors and frames based on the level of security required for specific openings. This standard considers two conditions, Forced Entry and Ballistic Resistance, or as is commonly known as “FE/BR”. There are tests described by this specification which are to be conducted in accordance with; SD-STD-01.01, Revision G; “Certification Standard on Forced Entry and Ballistic Resistance of Structural Systems”; ASTM F3038, “Standard Test Methods for Timed Evaluation of Forced-Entry-Resistant Systems”; and UL Standard 752, “Bullet Resisting Equipment”; and LPS 1175: “Specification for Testing and Classifying the Burglary Resistance of Building Components, Strong Points and Security Enclosures”.

The following are brief descriptions of the bullet resistance and the forced entry tests commonly specified for FE/BR products and systems:

The bullet resistance test is conducted in accordance with UL Standard 752 and SD-STD-1.01, Rev. G. These standards cover bullets fired from super power rated handguns to high-powered rifles “Bullet

resisting” signifies protection against complete penetration, passage of fragments of projectiles, or spalling (fragmentation) of the protective material to the degree that injury would be caused to a person standing directly behind the bullet resisting barrier.

The forced entry attack tests demonstrate a “real world” battery of tests where a team of persons actually attacks the face of the assembly and the hinge and locking elements using a host of tools and equipment provided for testing in accordance with the rating classification required.

CONSTRUCTION

The construction of FE/BR security hollow metal varies much depending upon the rating classification required. Also, many manufacturers that have tested to these standards guard the construction of their products with patents or proprietary information. The ensuing specification denotes recommended material thickness, how the doors and frames are to be welded, how and where hardware reinforcements are to be used, and how the product are to be finished and packaged for shipment.

Such prescriptive requirements are not intended to restrict innovative design. This is essentially a performance-based specification, and alternative constructions are to be permitted so long as the manufacturer demonstrates successful completion of the prescribed test requirements and associated certifications.

To summarize, this Specification recommends that the stated minimum material and fabrication requirements herein be followed, and that adherence to the manufacturer’s certified designs is also required.

FOREWORD

These specifications have been prepared in accordance with CSI recommended format with Part 1 - General, Part 2 -Product, and Part 3 -Execution. Guide specifications are intended to be used as the basis for developing job specifications and are to be edited to fit specific job requirements. Inapplicable provisions are to be deleted, appropriate selections are to be made where there are choices, and provisions applicable to the job are to be added where necessary. Optional items or requirements are shown in brackets. Notes and instructions to specifiers are given in italics directly following or at the start of the section to which they apply. Notes that contain permissive language are not considered part of the standard. The standards listed in this Guide are referenced by basic designation only. The edition of a Standard is noted as that in effect on the publication date this Guide, unless specifically noted otherwise. If a more recent standard is available, the specifier should verify its applicability to this guide prior to its inclusion.

Note: While the CSI Section Format locates Delivery, Storage, and Handling in Part 1, NAAMM Standards include them under Part 3 - Execution.

Materials and fabrication methods are specified in detail in Part 2. FE/BR Security Hollow Metal made in accordance with these specifications have successfully met the testing and performance requirements of Section 1.05. However, the materials and fabrication methods called for in these specifications, while providing a sound guide, are not meant to restrict the use of other materials and methods where it can be demonstrated through the specified testing procedures in Section 1.05 that the construction can equal or exceed the performance levels specified in this Section. In order to ensure that a manufacturer’s product meets the desired performance levels, the construction specifications must include the testing and performance requirements of Section 1.05 and the quality requirements of Section 1.06.

The values stated in inch-pound units are to be regarded as the standard. Corresponding metric values are included in parentheses for reference purposes only.

CSI SECTION 08 34 53 SECURITY DOORS AND FRAMES

PART 1 – GENERAL

1.01 SUMMARY

This section includes FE/BR security hollow metal [bullet resistant] [forced entry resistant] assemblies as scheduled in the contract documents and as specified herein.

1.02 PRODUCTS PROVIDED UNDER THIS SECTION

- A. FE/BR security hollow metal [bullet resistant] [forced entry resistant] doors [with 3 hour, 1-1/2 hour, 3/4 hour, 1/3 hour fire rating], swinging type as scheduled in the contract documents and as specified herein.
- B. Include [glazing molding and stops] [louvers] [speaking devices] [other] in FE/BR security hollow metal [bullet resistant] [forced entry resistant] doors as scheduled in the contract documents and specified herein.
- C. FE/BR security hollow metal [bullet resistant] [forced entry resistant] frames [for 3 hour, 1-1/2 hour, 3/4 hour, 1/3 hour fire rating] with anchors.
- D. Include [glazing molding and stops] [pass through devices] in FE/BR security hollow metal [bullet resistant] [forced entry resistant] frames as scheduled in the contract documents and specified herein.
- E. FE/BR security hollow metal [bullet resistant] [forced entry resistant] panels [with 3 hour, 1-1/2 hour, 3/4 hour, 1/3 hour fire rating] of the same construction as the FE/BR security doors.

Indicate bullet resistant/forced entry resistant doors, frames and panels only if applicable to the job. If these are to be fire-rated doors, frames and panels, indicate the required rating. Also indicate those items in 1.02.B and 1.02.D, which need to be included with the doors.

1.03 RELATED SECTIONS

- A. Section 01 66 00 – Product Storage and Handling
- B. Section 03 30 00 – Cast in Place Concrete
- C. Section 04 20 00 – Unit Masonry
- D. Section 05 10 00 – Structural Metal Framing (for Lintels, Posts, Columns or Other Load Bearing Elements)
- E. Section 06 11 00 – Wood Framing
- F. Section 08 11 19 – Stainless Steel Doors and Frames
- G. Section 08 34 73 – Sound Control Doors and Frames
- H. Section 08 71 00 – Door Hardware
- I. Section 08 71 20 – Weather Stripping and Seals
- J. Section 08 80 00 – Glazing
- K. Section 09 20 00 – Plaster and Gypsum Board (for the Installation of FE/BR Hollow Metal Doors and Frames in Steel Stud Partitions).
- L. Section 09 90 00 – Painting and Coating
- M. Section 11 19 00 – Detention Equipment
- N. Section ___ ___ ___ – Field Measurements
- O. Section 08 11 13 Hollow Metal Doors and Frames

Not included in this section are installation of doors, frames, panels, door hardware or rough hardware of any kind, weather-stripping, gasketing, operable windows, items furnished by others, field painting and protection at the building site of products furnished under this section.

1.04 REFERENCES The Standards listed in this Guide are referenced by basic designation only. Use the edition of a Standard that is in effect on the publication date this Guide, unless specifically noted otherwise. If a more recent standard is available, the specifier should verify its applicability to this guide prior to its inclusion.

- A. ANSI A 250.10, Standard Test Procedure and Acceptance Criteria for Prime Painted Steel Surfaces for Steel Doors and Frames
- B. ANSI / NAAMM HMMA 801, Glossary of Terms for Hollow Metal Doors and Frames
- C. ANSI / NAAMM HMMA 840, Installation and Storage of Hollow Metal Doors and Frames
- D. ANSI / NAAMM HMMA 866, Guide Specifications for Stainless Steel Hollow Metal Doors and Frames
- E. ANSI / NFPA 80, Fire Doors and Windows
- F. ANSI / NFPA 105, Standard for the Installation of Smoke Control Door Assemblies
- G. ANSI / NFPA 252, Standard Methods of Fire Tests of Door Assemblies
- H. ANSI / NFPA 257, Methods for Fire Test of Window Assemblies
- I. ANSI / UL 9, Fire Tests of Window Assemblies
- J. ANSI / UL 10B, Fire Tests of Door Assemblies
- K. ANSI / UL 10C, Standard for Positive Pressure Fire Tests of Door Assemblies
- L. ASTM A 653 / A 653M, Specification for Steel Sheet, Zinc-coated (Galvanized) or Zinc-Iron Alloy-Coated (Galvannealed) by the Hot Dipped Process, (FE/BR Steel)
- M. ASTM A 666, Standard Specification for Annealed or Cold-Worked Austenitic Stainless Steel Sheet, Strip, Plate and Flat Bar.
- N. ASTM A 1008 / A 1008M, Specification for Steel, Sheet, Cold-Rolled, Carbon, Structural, High-Strength Low-Alloy and High-Strength Low-Alloy with Improved Formability
- O. ASTM A 1011 / A 1011M, Specification for Steel, Sheet and Strip, Hot-Rolled, Carbon, Structural, High-Strength Low-Alloy, High-Strength Low-Alloy with Improved Formability, and Ultra-High Strength
- P. ASTM C 143 / C 143M, Standard Test Method for Slump of Hydraulic Cement Concrete
- Q. ASTM F 3038, Test Method for Timed Evaluation of Forced-Entry-Resistant Systems
- R. ASTM F 3217, Standard Guide for Security Fasteners
- S. CAN/ULC-S104, Standard Method for Fire Tests of Door Assemblies
- T. CAN/ULC-S106, Standard Method for Fire Tests of Window and Glass Block Assemblies
- U. NAAMM HMMA 803, Steel Tables
- V. NAAMM/HMMA 805, Recommended Selection and Usage Guide for Hollow Metal Doors and Frames
- W. NAAMM HMMA 820, Hollow Metal Frames
- X. NAAMM HMMA-820 TN01, Grouting Hollow Metal Frames
- Y. NAAMM HMMA 850, Fire-Rated Hollow Metal Doors and Frames, Second Edition AA.
- Z. UL 752, Bullet Resisting Equipment
- AA. UL 1784, Standard for Air Leakage Tests of Door Assemblies, 3rd Edition.

AB. NAAMM HMMA 850, Fire-Rated Hollow Metal Doors and Frames, 3rd Edition

AC. LPS 1175, Specification for Testing and Classifying the Burglary Resistance of Building Components, Strong Points and Security Enclosures (see LPC Loss Prevention Council)

AD. State Department Standard SD-STD-01.01, Revision G, Certification Standard for Forced Entry and Ballistic Resistance

1.05 TESTING AND PERFORMANCE

These test methods are intended to evaluate simulated forced entry resistance of a door and frame assembly to attacks using battering devices, common hand tools, powered hand tools, static loading, and bullets. These test methods are not to provide a measure of resistance for door and frame assemblies subjected to attack by corrosive agents.

The primary purpose of these test methods is to approximate the levels of abuse to which door and frame assemblies can be subjected in the course of a forced entry attack. The desired result of its use is to help ensure the protection to both public and private property and the safety of the inhabitants or occupants of the building where these door and frame assemblies will ultimately be used.

It is recommended that architects and building design personnel decide which security rating is required for each opening.

A. Test Samples

1. Construct test sample door and frame assemblies in accordance with Part 2 of this specification.
2. Permanently mark the test samples and retain them at the manufacturing facility for future reference for a period of one (1) year from date tested. Engage an independent testing agency to verify all tests. Include photographs of the testing apparatus and installation instructions including templates for the items of hardware used.

B. Specimen Preparation

1. Construct the test door assemblies consisting of single/double doors, frames, mulled systems and all hardware components such that they are representative of the application under investigation and the desired security classification needed for the application. Use the same basic construction and size of test doors and assemblies for all tests. Equip each test door with a vision panel, deal tray, or other features or options if applicable.

C. Forced Entry Fixturing

1. Install the wall and door assembly in a fixture typically constructed from steel tube, I-beam and angles. Construct this fixture such that it simulates the rigidity normally provided to a door assembly in a building by the ceiling, floor and walls in accordance with the applicable forced entry test standard.
2. Construct a rigid vertical test wall that is suitable for mounting the door and frame assembly in its normal attitude. Construct the wall section in such a manner that it will not contribute to the deflection of the door and frame assembly during bullet resistance and forced entry testing.
3. Mount the door and frame assembly under test in the rough opening in accordance with the manufacturer's installation instructions. Secure any opening elements in their optimum locked condition as appropriate.

D. Procedures

1. Bullet Penetration

- a. When specified by the contract documents, test door assemblies for bullet penetration resistance in accordance with UL-752 or SD-STD-01.01, Rev. G.
- b. Conduct testing of door, frame, hardware, security glazing, and other features and options as an assembly in accordance with UL-752 or SD-STD-01.01, Rev. G.
- c. If testing in accordance with UL-752 is specified, meet the level of performance rating required in accordance with Table 1.

TABLE 1

Ratings of Bullet Resistant materials as identified by: UL 752						
Rating	Ammunition	Weight (grains)	Weight (grams)	Min fps	Max fps	No. of shots
Level 1	9mm Full Metal Copper Jacket with Lead Core	124	8.0	1175	1293	3
Level 2	.357 Magnum Jacketed Lead Soft Point .	158	10.2	1250	1375	3
Level 3	.44 Magnum Lead Semi-Wadcutter Gas Checked	240	15.6	1350	1485	3
Level 4	.30 Caliber Rifle Lead Core Soft Point (.30-06 Caliber)	180	11.7	2540	2794	1
Level 5	7.62mm Rifle Lead Core Full Metal Copper Jacket Military Ball (.308 Caliber)	150	9.7	2750	3025	1
Level 6	9mm Full Metal Copper Jacket with Lead Core	124	8.0	1400	1540	5
Level 7	5.56mm Rifle Full Metal Copper Jacket with Lead Core (.223 Caliber)	55	3.56	3080	3383	5
Level 8	7.62mm Rifle Lead Core Full Metal Copper Jacket Military Ball (.308 Caliber)	150	9.7	2750	3025	5
Level 9	.30-06 caliber rifle, steel core, lead point filler, FMJ (APM2)	166	10.8	2715	2987	1
Level 10	.50 caliber rifle, lead core FMJ Military Ball (M2)	709.5	45.9	2810	3091	1
Shotgun	12-Gauge Rifled Lead Slug	1 Oz.	28.3	1585	1744	3
	12-Gauge 00 Buckshot (12 pellets)	1.5oz	42	1200	1320	3

2. Forced Entry Attack Test

- a. This test is designed to evaluate the resistance to physical attack of FE/BR security door and frame assemblies prepared for hardware and other options.
- b. This test is intended to simulate actual field conditions whereby an assailant or group of assailants has full access to certain handheld tools, and attacks the door face, hinge elements, locking elements, glazing, and other features in an attempted forced entry.
- c. Apparatus: Use the test fixture and wall described in Section 1.05.C in this test.
- d. Procedure: Install and test door and frame and/or window assemblies in accordance with LPS 1175, "Specification for Testing and Classifying the Burglary Resistance of Building Components, Strongpoints and Security Enclosures", or SD-STD-01.01, Revision G, "Certification Standard for Forced Entry and Ballistic Resistance of Structural Systems", or ASTM F3038, "Test Method for Timed Evaluation of Forced-Entry-Resistant Systems".

E. Labeled Fire-Rated Doors and Frames

1. Doors, frames, transom frames and sidelight assemblies provided for openings requiring fire protection, temperature rise, and/or smoke and draft control which are listed and/or classified and bear the label of a testing agency having a factory inspection service. Test the product in accordance with [ANSI/NFPA 252 or ANSI/UL-10B or CAN/ULC-S104] [ANSI/UL-10C] [UL 1784 or in accordance with ANSI/NFPA 105] and constructed as listed or classified for labeling. The architect determines and schedules the Fire, temperature rise and/or smoke and draft control ratings.
2. Provide window frames for openings requiring fire protection ratings which are listed and bear the label of a testing agency having a factory inspection service. Test frames in accordance with ANSI/UL 9 or [ANSI/NFPA 257 or CAN/ULC-S106] and construct frames as listed for labeling. The architect determines and schedules fire and/or smoke and draft control ratings.

UL 10C provides for positive pressure testing to accommodate the requirements of some jurisdictions and should be included only for such.

UL 1784 and ANSI/NFPA 105 provides for smoke and draft control assembly testing to accommodate these specific requirements, and should be included only when required.

Include CAN4-S104 and CAN4-S106 only for projects requiring conformance with Canadian Building Codes.

3. Advise the architect in the submittal documents if any door or frame product specified to be fire-rated cannot qualify for labeling because of design, hardware or any other reason. Advise the architect of hardware, glazing, or other options that affect the fire-rating and that were unknown at the time of submittal document preparation.

For additional information, refer to NAAMM HMMA 850, "Fire-Rated Hollow Metal Doors and Frames"

F. Prime Paint Performance (ANSI A250.10)

1. Meet acceptance criteria described in ANSI A250.10.
2. Include a description of the test specimens, procedures used in testing in all test reports and certificates of compliance, and indicate compliance with the contract documents specified acceptance criteria.

1.06 QUALITY ASSURANCE

A. Manufacturer's Qualifications

1. Provide evidence of having personnel and plant equipment capable of fabricating hollow metal door and frame assemblies of the type specified herein.
2. Provide evidence of having a written quality control system in place.

B. Quality Criteria

Provide that all doors, frames, and assemblies meet the requirements of Section 1.05 of these specifications. Fabricate in strict accordance with the approved submittal drawings. Provide that fabrication methods and product quality meet standards set by the Hollow Metal Manufacturers Association, HMMA, a division of the National Association of Architectural Metal Manufacturers, NAAMM, as set forth in the contract documents and NAAMM's HMMA 800 through 850 Series documents.

1.07 SUBMITTALS

- A. Submittal Drawings
 - 1. Show dimensioned door and frame elevations and sections.
 - 2. Show listing of opening descriptions including locations, thicknesses, and anchors.
 - 3. Show location and details of openings.
 - 4. Indicate FE/BR ratings on the submittal as they are shown on the contract documents and in the door schedule.
- B. Samples (if required)
 - 1. Door: 1 ft x 1 ft (305 mm x 305 mm) corner section with hinge mortise and reinforcement showing internal construction.
 - 2. Frame: 1 ft x 1 ft (305 mm x 305 mm) corner section showing welding of head to jamb. Include hinge mortise, reinforcement and grout guard in one rabbet, and glazing stop applied as specified in the opposite rabbet. Apply glazing stop in both head and jamb section to show corner joint.
 - 3. Fabricate samples for submission that are of the production type and that represent in all respects the minimum quality of work to be furnished by the manufacturer. Do not proceed with any work represented by the samples until the samples are approved. Any deficiency of quality compared to the approved samples may be cause for rejection of the work.
- C. Test Report Required from the Manufacturer
 - 1. Submit to the Architect upon request, an independent testing laboratory report certifying that door and frame assemblies meet the performance requirements of Section 1.05 and are constructed in accordance with Sections 2.01 and 2.03 of these specifications.
- D. Manufacturer Qualifications
 - 1. Submit to the architect upon request, ten (10) days prior to bid date, his qualifications as required by Section 1.06.

PART 2 – PRODUCTS

2.01 STEEL

- A. Used in the fabrication of hollow metal door and frame products shall meet one, or more, of the following requirements *ANSI and ASTM Standards no longer utilize "gage" to define steel thickness.*

In this Specification steel is expressed in terms of minimum decimal inch (millimeter) thickness. Dimensions or size traditionally expressed in fractional inches are shown in decimal inches (millimeters). HMMA has developed a Table, NAAMM/HMMA 803 to summarize the imperial standards and their corresponding metric values.

- 1. Cold-rolled steel conforming to ASTM A1008/A 1008M, "Specification for Steel, Sheet, Cold-Rolled, Carbon, Structural, High Strength Low-Alloy and High Strength Low-Alloy with Improved Formability, Solution Hardened, and Bake Hardenable" and ASTM A 568/A 568M "Standard Specification for Steel, Sheet, Carbon, Structural, and High-Strength, Low Alloy, Hot-Rolled and Cold-rolled, General Requirements for."
- 2. Hot-rolled, pickled and oiled (HRPO) steel conforming to ASTM A 1011/A 1011M, "Specification for Steel, Sheet, Cold-Rolled, Carbon, Structural, High Strength Low-Alloy and High Strength Low-Alloy with Improved Formability, Solution Hardened, and Bake Hardenable" and ASTM A 568/A 568M "Standard Specification for Steel, Sheet, Carbon, Structural, and High-Strength, Low Alloy, Hot-Rolled and Cold-rolled, General Requirements for."

3. Zinc-coated steel conforming to ASTM A 653/A 653M, "Specification for Steel Sheet, Zinc Coated (Galvanized) or Zinc-Iron Alloy-Coated (Galvannealed) by the Hot-Dip Process" and ASTM A 924/A 924M, "Standard Specification for General Requirements for Steel Sheet, Metallic Coated by the Hot-dipped Process".

2.02 FE/BR SECURITY HOLLOW METAL DOORS

A. Construction:

Manufacture doors of the types, sizes, and construction in accordance with the contract documents, and meet the performance requirements of Section 1.05 where applicable. At the manufacturer's option, fabricate doors using alternate materials and methods of construction, which are permitted provided they meet the aforementioned performance base criteria.

1. Face sheet thickness and steel type

a. Interior

i. Face Sheets, steel thickness: [0.093 in. (2.3 mm)], [0.123 in. (3.1 mm)]

ii. Steel Type, [cold-rolled] [hot-rolled] or [zinc coated min A25 (ZF75)].

b. Exterior

i. Face Sheets, steel thickness: [0.093 in. (2.3 mm)], [0.123 in. (3.1 mm)].

ii. Steel Type, zinc-coated, coating designation: [A40 (ZF120)], [A60 (ZF180)], [(G40 (Z120)) or [(G60 (Z180))].

2. Join door face sheets at their vertical edges by a continuous weld extending the full height of the door.

Note: See "Weld, Continuous" and "Welded, Continuously" in ANSI/NAAMM HMMA 801, Glossary of Terms for Hollow Metal Doors and Frames.

3. Minimum nominal door thickness is 1-3/4 in. (44 mm). Fabricate doors such that they are neat in appearance and free from warpage or buckle. Form edge bends such that they are true and straight and of minimum radius for the thickness of metal used.
4. Fabricate internal door construction in accordance with the manufacturer's certified design as shown in the manufacturer's submittal package in accordance with Section 1.07 of this specification.
5. Reinforce the vertical edges continuously using steel, not less than the thickness of the face sheets extending the full length of the door. Close the top and bottom edges with a continuous channel, not less than the thickness of the face sheets and spot welded to face sheets a maximum of 4 in. (101 mm) o.c. Continuously weld the closing end channel to the vertical edge reinforcing at all four corners producing a fully welded perimeter reinforcing.
6. Fit the top end channel with an additional flush closing channel of not less than 0.053 in. (1.3 mm) thickness. Weld the flush closing channel in place at the corners and at the center.
7. Provide edge profiles on both vertical edges of doors as follows:
 - a. Single acting doors beveled 1/8 in.(3mm) in 2 in.(50.8 mm)
 - b. Sliding doors or equivalent square edge
8. Hardware reinforcements and preparation:
 - a. Consult the hollow metal manufacturer for specific hardware sets needed at each level of security.

- b. Mortise, reinforce, drill and tap doors at the factory for templated mortise hardware only, in accordance with the final approved hardware schedule and templates provided by the hardware supplier. Where surface mounted hardware, anchor hinges, thrust pivots, pivot reinforced hinges, or non-templated hardware apply, reinforce doors for drilling and tapping that is required to be done by others in the field.
- c. Minimum thickness for hardware reinforcements:
 - i. Full mortise hinges and pivots 0.167 in. (4.2 mm)
 - ii. Surface applied maximum security hinges 0.214 in. (5.4 mm)
 - iii. Strikes 0.167 in. (4.2 mm)
 - iv. Slide device hanger attachment. per device manufacturer’s recommendations
 - v. Lock fronts, concealed holders, or surface mounted closers 0.093 in.(2.3 mm)
 - vi. Internal reinforcements for all other surface applied hardware 0.093 in.(2.3 mm)
- d. In cases where electrically or electronically operated hardware is required, and where indicated on approved hardware schedule, provide conduit, hardware enclosures, and/or junction boxes within the door. Fabricate access plates, where required, of the same material and thickness as the door face sheet and fasten these access plates with not less than four (4) #832 tamper resistant machine screws, at a spacing not to exceed 6 in. (152 mm) o.c.

9. Glazing moldings and stops:

- a. Where specified, provide doors with steel moldings to secure glazing by others in accordance with security glazing sizes and thicknesses shown on the contract documents.
- b. Fabricate fixed glazing molding of not less than 0.123 in. (3.1 mm) material thickness. Weld fixed glazing molding to both face sheets 5 in. (127 mm) o.c. maximum.
- c. In FE/BR security glazing openings, provide pressed steel angle removable glazing stops of not less than 0.123 in. (3.1 mm)_material thickness. Fabricate angle stops such that they are mitered or notched; are tight fitting at the corner joints; and are secured in place using 1/4 – 20 or 1/4 – 28 button head tamper resistant machine screws with spacing necessary to satisfy the performance criteria outlined in Section 1.06, but not to exceed spacings of 2 in. (50.8 mm) from each end and 9 in. (228 mm) o.c.
- d. Treat the surface underneath the glazing stops for maximum paint adhesion and painted with a rust inhibitive primer prior to installation in the door.

Note: it is recommended that view window stop heights be specified to provide 1 in. (25.4 mm) security glazing engagement.

Refer to ASTM F3217 for information on best fastener composition and physical properties for the intended application.

10. Louvers:

Fabricate louvers of the welded inverted “V” or “Y” type construction, and such that they provide free air delivery as specified. Fabricate the louver opening such that it is flush, and uses interior channels of 0.093 in. (2.3 mm) minimum material thickness that are securely welded to the inside of both face sheets. Fabricate a rectangular louver such that it does not exceed 18 in. (457 mm) in width without being reinforced at its midpoint by a vertical rectangular steel bar at

least 0.25 in. x 1.50 in. (6.3 mm x 38 mm) or a vertical round steel bar at least 0.75 in. (19 mm) diameter. Fabricate the vanes of not less than 0.093 in. (2.3 mm) material thickness, and space them so that no rigid flat instrument can be passed through them. Provide insect screens and flattened expanded metal of not less than 0.093 in. (2.3 mm) material thickness on louvered doors in exterior locations where shown on approved submittal drawings.

11. Provide speaking devices that consisting of a rectangular pattern of round holes, no more than 0.25 in. (6.3 mm) dia., in both face sheets directly across from each other. Fabricate the rectangular hole pattern such that it is a minimum size of 1 in. (25 mm) high x 4 in. (101 mm) wide with holes spaced no more than 1 in. (25 mm) o.c. vertically and horizontally. Provide baffles in the interior of the door between the rectangular hole patterns using pressed steel sections, not less than 0.067 in. (1.7 mm) material thickness, such that no objects can be passed through.
12. Paper pass assemblies:
 - a. Fabricate the pass opening such that it is flush; is fabricated using interior channels 0.093 in. (2.3 mm) minimum material thickness; and is securely welded to the inside of both face sheets. Continuously weld the four corner seams and dress them smooth. Construct the finished opening such that it cannot be dismantled or otherwise affected by tampering or scraping.
 - b. Construct the pass shutter such that it conforms with the attack resistance as specified by the Architect and conform to that of the door/frame assembly.
 - c. Treat the shutters for maximum paint adhesion and give them a shop coat of rust inhibitive primer, and factory install them.

2.03 FE/BR SECURITY HOLLOW METAL PANELS

- A. Manufacture hollow metal panels of the same materials and construction, and finish these panels in the same way as specified in Sections 2.01 and 2.06.

2.04 FE/BR SECURITY HOLLOW METAL FRAMES

- A. Construction
 1. Fabricate frames, with the exception of cased openings such as for sliding doors, such that they have integral stops, and are welded units of the sizes and types shown on approved submittal drawings. Construct frames in accordance with these specifications, and such that they meet performance criteria specified in Section 1.05 where applicable. At the manufacturer's option, fabricate frames using alternate materials and methods of construction, which are permitted provided they meet the aforementioned performance criteria.

Thickness and Steel Type

Steel thickness and material type at manufacturer's option, unless specified.

- a. Interior
 - i. Frame steel thickness: [0.093 in. (2.3 mm)], [0.123 in. (3.1 mm)]
 - ii. Steel Type, [cold-rolled] [hot-rolled] or [zinc coated min A25 (ZF75)].
- b. Exterior
 - i. Frame steel thickness: [0.093 in. (2.3 mm)], [0.123 in. (3.1 mm)].
 - ii. Steel Type, zinc-coated, coating designation: [A40 (ZF120)], [A60 (ZF180)], [(G40 (Z120)) or [(G60 (Z180))].

2. Fabricate frames such that all finished work is neat in appearance, square, and free of defects, warps and buckles. Form pressed steel members such that they are straight and of uniform profile throughout their lengths.
3. Fabricate jamb, header and sill profiles in accordance with the frame schedule and as shown on the approved submittal drawings. Fabricate all frame sections, and assemble all frames in accordance with the manufacturer's certified design as shown in the manufacturer's submittal package in accordance with Section 1.07 of this specification.
4. Fabricate corner joints such that all of their contact edges are closed tight with faces mitered and stops either butted or mitered. Continuous weld faces and soffits (see Figure 1) and finish the faces smooth. The use of gussets or splice plates as a substitute for welding is not acceptable.
5. Continuously weld all other face joints and finish them smooth.
6. Minimum height of stops in door openings are required to be 0.625 in. (15.8 mm). Height of stops on security glazing or panel openings are required to be as shown on approved submittal drawings.
7. When shipping limitations so dictate, or when advised by the contractor responsible for coordination or installation, fabricate frames for large openings in sections designated for assembly in the field by others. Install alignment plates or angles at each joint. Fabricate such components the same material thickness as the frame. Fabricate field joints, which are to be field welded by others, in accordance with approved submittal drawings.
8. Fabricate frames for multiple openings using mullion members which, after fabrication, are closed shapes conforming to profiles shown on approved submittal drawings, and that have no visible seams or joints. Continuous weld and finish smooth all joints between faces of abutted. Weld all joints between stops of abutted members along the soffit such they are left neat and uniform in appearance.
9. Hardware Reinforcements and Preparation:
 - a. Consult the hollow metal manufacturer for specific hardware sets needed at each level of security.
 - b. Mortise, reinforce, drill and tap frames at the factory for all templated mortised hardware only, in accordance with the final approved hardware schedule and templates provided by the hardware supplier. Where surface mounted hardware, anchor hinges, thrust pivots, pivot reinforced hinges, or non-templated hardware apply, reinforce frames for drilling and tapping that is required to be done by others in the field.
 - c. Minimum thickness of hardware reinforcing:
 - i. Hinges and pivots 0.167 in. x 1.5 in. x 10 in. length
(4.2 mm x 38 mm x 254 mm)
 - ii. Surface applied maximum security hinges 0.214 in. (5.4 mm)
 - iii. Strikes 0.167 in. (4.2 mm)
 - iv. Closers. 0.167 in. (4.2 mm)
 - v. Flush bolts 0.167 in. (4.2 mm)
 - vi. All other surface applied hardware. 0.093 in.(2.3 mm)
 - d. In cases where electrically or electronically operated hardware is required, and where indicated on approved hardware schedule, provide hardware enclosures, and/or junction boxes. Fabricate access plates, where required, of the same material thickness as the frame and fasten these access plates with not less than four (4) #8-32 tamper resistant machine screws, not to exceed 6 in. (152 mm) o.c.

10. Floor Anchors:

- a. Where applicable, provide floor anchors with two (2) holes for fasteners and fasten them inside jambs with at least four (4) spot welds per anchor.
- b. Where so scheduled, install adjustable floor anchors, that provide not less than 2 in. (50 mm) height adjustment, and fasten them in place with at least four (4) spot welds per anchor.
- c. Fabricate floor anchors of the same material thickness as frame.

11. Jamb Anchors:

a. Anchor Spacing

Provide the number of anchors on each jamb as follows:

Borrowed light frames: 2 anchors plus 1 for each 18 in. (457 mm) or fraction thereof over 36 in. (914 mm), spaced at 18 in. (457 mm) maximum between anchors

Door frames: 2 anchors plus 1 for each 18 in. (457 mm) or fraction thereof over 54 in. (1372 mm), spaced at 18 in. (457 mm) maximum between anchors (fire ratings can require additional anchors)

b. Masonry Type

Provide frames for installation in masonry walls with adjustable jamb anchors of the strap and stirrup type made from the same thickness steel as frame. Fabricate straps such that they are no less than 2 in. x 10 in. (50.8 mm x 254 mm) in size, corrugated and/or perforated.

c. Embedment Masonry Type

- i. Provide frames for installation in pre-finished masonry or concrete openings with removable faces at the jambs, and 0.167 in. x 2 in. x 2 in. (4.2 mm) x 50.8 mm x 50.8 mm angle anchors 4 in. (102 mm) long spaced as described in Section 2.03.B.11.a. Locate the frame anchors to coincide with matching embedded anchors to be provided for installation in the wall.
- ii. Fabricate embedded wall anchors such that they consist of a 0.167 in. (4.2 mm) x 4 in. (102 mm) wide x 6 in. (152 mm) plate with 0.167 in. x 2 in. x 2 in. (4.2 mm) x 50.8 mm x 50.8 mm angle anchors 4 in. (102 mm) long welded in place at locations to match angle anchors in frames. Provide the embedded plate with two (2) #4 re-bar wall anchors 10 in. (254 mm) long minimum, with 2 in. (50.8 mm) x 90 degree turn down on ends continuously welded in place, and spaced as described in Section 2.04.11.a. Prime paint embedments in accordance with Section 2.07.B.
- iii. Fasten each angle anchor to jamb and to embedded plate with two (2) 1 in. (25.4 mm) long arc welds at each end of the anchor. Ship anchors separately from the frames.
- iv. Anchorage systems that require removable jamb faces are required to be disassembled in the field by the contractor responsible for installation. The installer is responsible for shimming at the anchor contact points prior to welding, using steel shims, to assure that the frame meets installation tolerance requirements specified in Section 3.02.A. The contractor responsible for installation is required to move the frames into the openings until the frame anchors contact and match the embedded anchors. The contractor responsible for installation is required to field weld all anchors and install the jamb faces in place. Provide embedment anchoring details on approved submittal drawings.

d. Expansion Bolt Type:

- i. Prepare frames for installation in existing masonry or concrete walls for expansion bolt type anchors. Fabricate the preparation such that it consists of a countersunk hole for a 0.5 in. (12.7 mm) diameter bolt and a spacer from the unexposed surface of the frame to the wall. Weld the spacer to the frame, and space the preparation as described in Section 2.04.11.a. Others are required to provide anchor fasteners.

- ii. After sufficient tightening of the bolt, the installation contractor is required to weld the bolt head so as to provide a non-removable condition. The welded bolt head is then ground, dressed, and finished smooth.
 - e. Construct frames to be installed in pre-finished concrete, masonry, or steel openings, and provide them with anchoring systems of suitable design as shown on the approved submittal drawings.
- 12. Provide grout guards at all hardware preparations, glazing stop screws, and silencer (mute) preparations on frames to be set in masonry or concrete openings. Provide grout guards that are sufficient to protect preparations from grout of a 4 in. (102 mm) maximum slump consistency which is hand troweled in place.
 - a. Install grout guards for glazing stop screws at the factory such that the exposed portion of the screws inside the frame throat, around the perimeter is covered. Where mullions are required to be grouted, protect screws inside mullions with grout guards.
 - b. Protect silencer (mute) preparations by grout guards where accessible from the frame throat. The contractor responsible for frame installation is required to furnish and install silencers (mutes).
- 13. Provide two (2) temporary steel spreaders welded to the bottom of the jambs of door frames to serve as bracing during shipping and handling. The installation contractor is responsible for finishing and touch-up of marks caused by spreader removal.
- 14. Removable glazing stops:
 - a. In openings where security glazing is specified and where shown on the approved submittal drawings, provide pressed steel angle glazing stops, not less than 0.123 in. (3.1 mm) thick. Fabricate angle stops such that they are mitered or butted and tight fitting at the corner joints, and are secured in place using machine screws of the size and spacing necessary to satisfy the performance criteria outlined in Section 1.05, but spaced not less than 2 in. (50.8 mm) from each end and 9 in. (228 mm) o.c.

Note: It is recommended that view window stop heights be specified to provide 1 in. (25.4 mm) security glazing engagement.

Refer to ASTM F3217 for information on best fastener composition and physical properties for the intended application.
 - b. Treat the surface underneath the glazing stops for maximum paint adhesion and paint these surfaces with a rust inhibitive primer prior to installation in the frame.

2.05 MANUFACTURING TOLERANCES

Note: The manufacturer of the doors and frames is responsible only for the manufacturing tolerances listed in 2.04. The final clearances and relationships between door and frame depends on the setting of the frame (see Figure 5) and the hanging and adjustment of the door and hardware (see Sections 3.02 and 3.03).

- A. Maintain manufacturing tolerance within the following limits:
 - 1. Frames for single door or pair of doors:
 - a. Width, measured between rabbets at the head: Nominal opening width + 1/16 in. (1.5 mm), - 1/32 in. (0.8 mm)
 - b. Height (total length of jamb rabbet): Nominal opening height + 1/16 in. (1.5 mm), - 1/32 in. (0.8 mm).

2. Cross sectional frame profile dimensions: (see Figure 2)
 - a. Face $\pm 1/32$ in. (0.8 mm)
 - b. Stop..... $\pm 1/32$ in. (0.8 mm)
 - c. Rabbet..... $\pm 1/32$ in. (0.8 mm)
 - d. Depth $\pm 1/16$ in. (1.5 mm)
 - e. Throat $\pm 1/32$ (0.8 mm)

Note: Frames overlapping walls to have throat dimension 1/8 in. (3.1 mm) greater than dimensioned wall thickness to accommodate irregularities in wall construction.
3. Flatness of large frames: 1/8 in (3.1 mm) in 10 ft (3048 mm) of length or width
4. Doors - Doors are undersized to fit the frame. Edge clearances are based upon individual door manufacturer's designs. Tolerance on actual door sizes are as follows:
 - a. Width $\pm 3/64$ in.(1.2 mm)
 - b. Height..... $\pm 3/64$ in.(1.2 mm)
 - c. Thickness..... $\pm 1/16$ in.(1.5 mm)
 - d. Edge Flatness $\pm 1/16$ in. (1.5 mm) maximum
 - e. Surface Flatness $\pm 1/8$ in.(3.2 mm) maximum
5. Hardware
 - a. Cutout and template dimensions..... $+ 0.015$ in.(0.38 mm), - 0
 - b. Location $\pm 1/32$ in.(0.8 mm)
 - c. Between hinge centerlines..... $\pm 1/64$ in.(0.4 mm)

2.06 HARDWARE LOCATIONS

Provide hardware locations in accordance with the manufacturer's certified design, and in accordance with the following minimum specifications:

Locate hardware on doors and frames as listed below. All dimensions except the hinge locations are referenced from the floor as defined in Section 3.03.

When security hollow metal frames are specified for use with doors to be furnished by others, hardware preparations on the doors are normally governed by the location on the frames as stated in 2.05.A.

- A. Hinges: Top 5 in.(127 mm) from underside of frame head rabbet at door opening to top of hinge
 - Bottom..... 10 in.(254 mm) from finished floor to bottom of hinge
 - Intermediate Centered between top and bottom hinges
- B. Locks and latches..... 38 in.(965 mm) to centerline of knob or lever shaft
- C. Deadlocks 46 in.(1168 mm) to centerline of cylinder
- D. Exit hardware 38 in.(965 mm) to centerline of cross bar or as shown on hardware template
- E. Door pulls 42 in.(1066 mm) to centerline of grip
- F. Push/pull bars..... 42 in.(1066 mm) to centerline of bar
- G. Arm pulls 46 in.(1168 mm) to centerline
- H. Push plates 46 in.(1168 mm) to centerline of plate
- I. Intercoms 48 in.(1219 mm) to centerline of intercom push button

Note: See NAAMM / HMMA 830 and 831 for additional information.

2.07 FINISH

- A. After fabrication, fill and sand all tool marks and surface imperfections as required to make face sheets, vertical edges and weld joints free from irregularities.
- B. After appropriate metal preparation, apply a rust inhibitive primer, which meets or exceeds the performance requirements of Section 1.05.F, to all exposed surfaces of doors and frames. For stainless steel finishes, refer to ANSI/NAAMM/HMMA 866.
- C. Primer must be fully cured prior to shipment.

All primer and finish paint must be formulated for Direct to Metal (DTM) application.

PART 3 – EXECUTION

Note: Proper storage and protection is essential to the proper performance of doors and frames. The requirements for proper storage are given in the following sections. However, it is important to recognize that proper storage is not the responsibility of the FE/BR security hollow metal manufacturer. For this reason, the requirements for storage and protection of detention hollow metal doors and frames should be included in that section of the specifications where installation of work is specified. For additional information regarding installation, see NAAMM / HMMA 840, “Guide Specifications for Installation and Storage of Hollow Metal Doors and Frames”. (Reference: HMMA 840 “Installation and Storage of Hollow Metal Doors and Frames”).

3.01 SITE STORAGE AND PROTECTION OF MATERIALS

- A. The contractor responsible for installation is required to remove wraps or covers from doors and frames upon delivery at the building site and to ensure that any scratches or disfigurement caused in shipping or handling are promptly sanded smooth, cleaned and touched up with a compatible rust inhibitive primer.
- B. The contractor responsible for installation is required to ensure that materials are properly stored on planks or dunnage in a dry location. Doors are required to be stored in a vertical position and spaced by blocking. Figure 3 illustrates recommended storage positioning. Materials are required to be covered to protect them from damage but in such a manner as to permit air circulation.

3.02 INSTALLATION

Note: Correct installation is essential to the proper performance of detention doors and frames. The requirements for proper installation are given in the following sections. However, it is important to recognize that installation is not the responsibility of the detention hollow metal manufacturer. For this reason, the requirements for installation of detention hollow metal doors and frames should be included in that section of the specifications where installation of work is specified. It is the responsibility of the general contractor using experienced personnel to perform the work outlined in this section. For additional information regarding installation, see NAAMM / HMMA 840, “Guide Specifications for Installation and Storage of Hollow Metal Doors and Frames”. (Reference: HMMA 840 “Installation and Storage of Hollow Metal Doors and Frames”).

- A. The installer is required to perform the following:
 - 1. Prior to installation, check the area of floor on which the frame product is to be installed, within the path of the door swing, for flatness.

2. Prior to installation, remove temporary spreaders. Check doors and frame product for correct size, swing, fire rating and opening number.
3. Prior to installation, isolate and protect all interior surfaces of perimeter frame product sections to be installed in masonry or concrete walls from grout and antifreeze agents.

The drawbacks and benefits associated with the use of water based masonry grouts, with or without antifreeze agents, should be carefully weighed during the detailing and specification process. Grouting of mullions and other closed sections is not recommended, and plaster based grouts should not be used. Refer to NAAMM HMMA Tech Note, HMMA 820 TN01-03, "Grouting Hollow Metal Frames", included as Appendix 2, for further guidance.

4. During the setting of frame product check and correct as necessary for opening width, opening height, squareness, alignment, twist and plumbness. Maintain installation tolerances within the following limits.
 - a. Opening Widthmeasured from rabbet to rabbet at top, middle and bottom of frame + 1/16 in (1.5 mm) – 1/32 in (0.8 mm)
 - b. Opening Heightmeasured vertically between the frame head rabbet and top of floor or bottom of frame minus jamb extensions at each jamb and across the head: + 1/16 in (1.5 mm) – 1/32 in (0.8 mm)
 - c. Squarenessmeasured at rabbet on a line from jamb, perpendicular to frame head; not to exceed 1/16 in (1.5 mm)
 - d. Alignmentmeasured at jambs on a horizontal line parallel to the plane of the face; not to exceed 1/16 in (1.5 mm)
 - e. Twistmeasured at opposite face corners of jambs on parallel lines perpendicular to the plane of the door rabbet; not to exceed 1/16 in (1.5 mm)
 - f. Plumbnessmeasured at the jambs on a perpendicular line from the head to the floor; not to exceed 1/16 in (1.5 mm)

The above tolerances provide a reasonable guideline for proper installation of hollow metal frame product. However, it should be noted that the cumulative effect of the installation tolerances at or near their maximum levels could result in sufficient misalignment to prevent the door from functioning properly. Installers should be careful not to create a tolerance buildup. Tolerance buildup occurs when several tolerances are at or near their maximums.

5. The details in Figure 4 and Figure 5 illustrate the method of measuring the above specified tolerances.
6. Grout guards and junction boxes are intended to protect hardware mortises and tapped holes from masonry grout of 4 in. (101 mm) maximum slump consistency which is hand troweled in place. If a lighter consistency grout (greater than 4 in. (101 mm) slump when tested in accordance with ASTM C 143/C 143M) is to be used, special precautions must be taken in the field by the installer to protect the aforementioned.
7. Frame products are not intended or designed to act as forms for grout or concrete. Grouting of hollow metal sections are required to be done in "lifts" or precautions otherwise taken by the contractor to ensure that frames are not deformed or damaged by the hydraulic forces that occur during this process.

8. Keep hollow metal surfaces free of grout, tar and/or other bonding materials or sealers. Promptly clean off grout, tar, and/or bonding materials or sealers from frame product and doors.
9. Finish and touch-up marks caused by spreader removal.
10. Promptly finish smooth, clean, treat for maximum paint adhesion, and touch up with a rust inhibitive primer all exposed hollow metal surfaces which have been scratched or otherwise marred during installation, cleaning, and/or field welding. Use a primer that is comparable to and compatible with the shop applied primer and finish paint specified in Section 09 90 00 [09900]. All touch-up primer and finish paint must be formulated for Direct to Metal (DTM) application.
11. Install labeled fire doors and frame product in accordance with the terms of their listings, ANSI/NFPA 80, or the local Authority Having Jurisdiction.
12. Proper door edge clearances must be maintained in accordance with Section 3.03, except for special conditions otherwise noted. Where necessary, metal hinge shims, furnished by installer, are permitted to maintain clearances.
13. Apply hardware in accordance with hardware manufacturer's templates and instructions.
14. Finish paint in accordance with Section 09 90 00 [09900].
15. Install door silencers (mutes).
16. Install glazing materials in accordance with Section 08 80 00 [08800].

3.03. CLEARANCES

- A. Edge clearance for swinging hollow metal doors are required to be a minimum of 1/32 in (0.8 mm) in order to provide for the functional operation of the assembly and are required to not exceed the following:
 1. Between doors and frame product at head and jambs 3/16 in. (4.7 mm)
 2. Between edges of pairs of doors 3/16 in. (4.7 mm)
 Edge clearance for labeled fire doors and frames is covered by 3.02.A.11.
- B. Floor clearance for swinging hollow metal doors are required to not exceed the following:
 1. At bottom of door where threshold in used 3/8 in. (9.5 mm) from bottom of door to top of threshold
 2. At bottom of door where no threshold is used. 3/4 in. (19.1 mm) above floor
 3. Between bottom of door and nominal surface of floor coverings at fire-rated openings, as provided in ANSI/NFPA 80 1/2 in. (12.7 mm)

Note: The architect must define the distance from top of the floor/finished floor to top of floor covering so appropriate undercuts can be provided. Floor/Finish Floor is defined as the top of the concrete or structural slab. HMMA uses the term "top of floor covering" to describe the NFPA term "nominal surface of floor covering." Refer to HMMA's Tech Note, HMMA 810 TN01-03, "Defining Undercuts," included as Appendix 3 for further guidance.

APPENDIX

X1. GUIDELINES FOR USE

X1.1 FORCED ENTRY AND BALLISTICS RESISTANCE OF WINDOWS, DOORS, AND NON-WINDOW OPENINGS

X1.1.1 This guide specification was developed to provide architects and owners the background and guidance to specify the security performance and testing requirements of building envelope elements based upon the level of security required for each opening, and considering two (2) criteria, Forced Entry Resistance and Ballistics Resistance. There are many other aspects of physical security, however, this standard addresses only these two considerations.

X1.1.2 Forced Entry and Ballistic Resistant (FEBR) doors, windows, sidelight and multiple light glazed systems should be specified and tested under ANSI/NAAMM/HMMA-862, "Guide Specifications for FE/BR Security Hollow Metal Doors and Frames". Although HMMA-862 is written to address doors and glazed openings, the forced entry testing and the ballistics testing that is described throughout is readily adaptable and routinely performed on other exterior opening protectives, such as, Deal Trays, Pass Drawers, HVAC louvers, grilles, and roof hatches.

X1.1.3 There are tests recommended by this specification which are conducted in accordance with; SD-STD-01.01, Revision G; "Certification Standard on Forced Entry and Ballistic Resistance of Structural Systems"; UL Standard 752, "Bullet Resisting Equipment"; and LPS 1175; Issue "Specification for Testing and Classifying the Burglary Resistance of Building Components, Strong Points and Security Enclosures", and ASTM F3038. As previously mentioned, the focus of these standards are forced entry and bullet resistance (FEBR).

X1.1.4 The bullet resistance test is conducted in accordance with UL Standard 752 or SD-STD-01.01, Rev. G. These standards cover bullets fired from various calibers of handguns up to high-powered rifles using armor-piercing ammunition, typically the military rounds 5.56 mm and 7.62 mm. "Bullet resisting" signifies protection against complete penetration, passage of fragments of projectiles, or spalling (fragmentation) of the protective material to the degree that injury would be caused to a person standing directly behind the bullet resisting barrier. UL-752 also addresses other calibers of weapons that could be subjects of testing, and these are detailed in Table 1, Section 1.05.D.

X1.1.5 The forced entry attack tests consists of a "real world" battery of tests whereby a testing team actually attacks the face of the assembly, the hinge and locking elements, along with glazing and other features using a host of tools and equipment in accordance with the rating classification required, and the test is conducted for a prescribed time period on each element of the assembly.

X1.1.5.1 Security ratings in minutes ranging from 5 to 60 minutes refer to testing procedures set forth by either the Loss Prevention Standard LPS 1175, or the SD-STD-01.01, Rev G, certification standard for Forced Entry, and ASTM F3038 Test Method for Timed Evaluation of Forced-Entry-Resistant Systems.

X1.1.5.2 Forced Entry testing procedures under the U.S. Department of State (DOS) standard, SD- STD-01.01, Rev.G, call for a "concentrated assault" on edges, seams and other predicted vulnerable locations on the test sample, and in accordance with direction from the test director. The attack team consists of six (6) people of specified range of size, condition and age. The standard provides for one set of tools available to the attack team, which are listed in Table 2, and by policy, DOS has established three (3) classifications, 5, 15 and 60 minute. Forced Entry ratings of 15 and 60 minutes include Bullet Resistance testing conducted on the test sample prior to the timed forced entry attempt. Bullet resistance testing is not required, however is optional, for the 5 minute classification.

X1.1.5.3 Forced Entry procedures conducted under the Loss Prevention Council standard, LPS-1175, call for "manual intervention" on building components, strong points and enclosures, again, employing an attack team operating under the direction of a test director. The LPS standard has established six (6) classifications, each classification requiring attacks to be conducted over incrementally increasing time periods, 5 minutes through 60 minutes. The number and capabilities of the tools available to the attack team are incrementally upgraded as one moves up the scale

such that there are six (6) “Tool Categories”, A through F, corresponding to the six (6) security ratings. Security grade 1 calls for Tool Category A, 2 calls for B, and so on. These Tool Categories are listed in Table 3. The attack team consists of two (2) people for rating #1, four (4) for rating #2, and six (6) for ratings #3 through #6. There is no bullet resistance testing incorporated into LPS 1175.

X1.1.5.4 Although, the forced entry testing procedures under LPS-1175 and SD-STD-01.01 vary with regard to personnel, tools and bullet resistance considerations, both have generally been considered comparable within the security products and systems industry and certifications under either have been considered acceptable.

X1.1.5.5 Another forced entry standard, ASTM F3038, was developed by ASTM committee F12, and was recently published in 2014. As a matter of background, ASTM F3038 is sometimes specified as a substitute for the U.S. Department of State standard for Forced Entry testing, SD-STD-01.01, Rev. G. F3038 is basically another “real world” forced entry test method, but the following considerations as compared to SD-STD-01.01, Rev. G. should be taken into account:

X1.1.5.5.1 Forced Entry testing procedures under the U.S. Department of State (DOS) standard, SD-STD-01.01, Rev.G, call for a “concentrated assault” on edges, seams and other predicted vulnerable locations on the test sample, and in accordance with direction from the test director. The attack team consists of six (6) people of specified range of size, condition and age. The standard provides for one set of tools available to the attack team, which are listed in Table 2, and by policy, DOS has established three (3) classifications, 5, 15 and 60 minute. **It is important to understand that Forced Entry ratings of 15 and 60 minutes include Bullet Resistance testing conducted on the test sample prior to the timed forced entry attempt, which adds a level of difficulty, as well as realism, to the overall tests that is not included in either ASTM F3038 or LPS 1175. Neither of these standards require bullet resistance testing on the forced entry test sample before or after the timed forced entry attempt is conducted.**

X1.1.5.5.2 Although, the forced entry testing procedures under SD-STD-01.01, Rev. G, and ASTM F3038 vary with regard to personnel, tools and bullet resistance considerations, the DoS standard has generally been considered the ultimate forced entry testing procedure within the security products and systems industry, and certifications under either have been considered acceptable. This is stated in ASTM F3038, Appendix X.5 “Equivalency of Standard”.

X1.1.6 It is noteworthy that there are several other forced entry related standards in use worldwide that do not specifically address anti-terrorism, but do address burglary resistance along with other forced entry scenarios. Therefore, the applications that are typically related to these standards are usually not applicable to what is generally thought of as protection of people and assets against the armed assault and destruction that is associated with terrorism. Two examples of burglary resistance standards, neither of which include bullet resistant testing, are as follows:

X1.1.6.1 BS EN 1627, “Pedestrian doorsets, windows, curtain walling, grilles and shutters. Burglar resistance. Requirements and classification (British Standard)”, first paragraph of the scope statement as follows:

This European Standard specifies requirements and classification systems for burglar resistant characteristics of pedestrian doorsets, windows, curtain walling, grilles and shutters. It is applicable to the following means of opening: Turning, tilting, folding, turn-tilting, top or bottom hung, sliding (horizontally and vertically) and rolling as well as fixed constructions. It also covers products that include items such as letter plates or ventilation grilles. It specifies requirements for the burglar resistance of a construction product (as defined in 3.1 of this standard).

X.1.1.6.1.1 Annex C, “Resistance Classes – Classification according to EN 1627” offers an explanation regarding the six (6) classifications and their relationship to descriptions of levels of burglary attempts. These range from attempts by the “casual burglar” described in Class 1 to attempts by an “experienced professional” well equipped burglar as described in Class 6.

X.1.1.6.1.2 More detail is presented in Table C.1, “Anticipated Method and Attempts to Gaining Entry”, from Class 1 through Class 6, including brief descriptions of increasing capabilities of tools and effectiveness of methods (more detail is provided in EN 1630) as well as the burglar’s increasing acceptance of risk in return for the higher levels of reward.

X.1.1.6.2 BS EN 1630, “Pedestrian doorsets, windows, curtain walling, grilles and shutters. Burglar resistance. Test method for the determination of resistance to manual burglary attempts (British Standard)”, first paragraph of the scope statement as follows:

This European Standard specifies a test method for the determination of resistance to manual burglary attempts in order to assess the burglar resistant characteristics of pedestrian doorsets, windows, curtain walling, grilles and shutters. It is applicable to the following means of opening: Turning, tilting, folding, turn-tilting, top or bottom hung, sliding (horizontally and vertically) and rolling as well as fixed constructions.

X.1.1.6.2.1 Table 2 begins descriptions of tool sets that are used in the burglary attempt test procedures. Tool Set A1 is used for Class 1 testing and so on up through Tool Set A6 used for Class 6 testing. The steady increase in tool capabilities as well as test durations provides for burglary attempt simulations that closely match steadily increasing “real world” threats described in Annex C of EN 1627.

X.1.1.6.2.2 Annex A, “Tool Sets”, provides informative descriptions and photos of the tools associated with each Tool Set demonstrating the tool capabilities that are available to test personnel depending upon the product Classification that is being sought.

X1.1.7 Fire Testing: Where openings require fire ratings and where fire ratings are specified by the contract documents of the building project, protective assemblies for those openings, such as, doors, frames, borrowed lights and side-lights are fire tested in accordance with test method UL-10C or NFPA 252. Windows are tested in accordance with UL-9C or NFPA-257. The pass/fail criteria and criteria for assignment of fire ratings are in accordance with the applicable test methods. The manufacturers of rated or listed products maintain their product listings and manufacturing procedures under the auspices of the fire testing laboratory, such as, Underwriters’ Laboratories (UL) or Intertek Testing Services (ITS). Information regarding available fire rated FEBR products is typically available from the laboratories through their websites and through their Building Materials Directories.

TABLE 2

FORCED ENTRY TEST RESOURCES (From SD-STD-01.01 Rev. G)

Resource	Description	Quantity Each		
		<u>Specified Protection Level</u>		
		5 min.	15 min.	60 min.
Active Personnel		2	6	6
Sledgehammer	12 lbs. 30 inches long		2	2
Sledgehammer	10 lbs., 30 inches long	2		
Carpenter Hammer	3 lbs.	2	2	2
Carpenter Hammer	1 lb.	2	2	2
Ram(a)	120 lbs., 2 man, 4 x 4 inches	1	1	1
Wood Splitting Maul (b) (d)	9 lbs., 35 inches long		1	1
Wood Ax, Single Bit (b) (e)	3-1/2 lbs., 36 inches long		1	2
Crowbar, Pinch Bar	60 inch		2	2
Crowbar, Ripping Bar	48 inch	1	2	2
Crowbar	24 inch		2	2
Wedge, Wood Splitting (b)	9 x 2-1/2 inches	2	4	4
Hacksaw	12 inch		2	2
Keyhole Saw (c)	Wood, 12 inch	1	1	1
Bolt Cutters	48 inch		1	1
End Nippers	14 inch	1	1	1
Chisel, Cold (b)	1 inch	1	2	2
Chisel, Cold (b)	3/4 inch	1	2	2
Chisel, Masonry (b)	2-1/4 inch	1	2	2
Screwdriver, Flat Blade	10 inch		2	2
Screwdriver, Flat Blade	Medium 1/4 inch		2	2
Screwdriver, Phillips	10 inch		2	2
Screwdriver, Phillips	No. 1		2	2
Channel Locks	10 inch	1	1	1
Adjustable Wrench	15 inch		1	1
Adjustable Wrench	10 inch		2	1
Punch	3/8 inch		1	1
Punch	1/4 inch		1	1
Torch, Propane (c)	Portable		1	1
Vice Grip	12 inch	1	1	1
Push Broom	Wooden	1	1	1

(a) Impact area: 4 x 4 inches (± 0.25 inches)

(b) Sharp edged tools shall not be re-sharpened during the test.

(c) Used only during the test to failure phase.

(d) The Wood Splitting Maul shall not be used when testing transparent portions of test samples.

(e) The Wood Ax shall be used only during the final five (5) minutes when testing transparent portions of test samples.

These tools are sizes commonly available in the U.S. For SI (metric) equivalents, convert as follows: one (1) inch = 25.4 mm, one (1) lb. = 0.454 kg. Round in accordance with FED-STD-376A, Preferred Metric Units for General Use by the Federal Government, 5 May 1983.

TABLE 3

LPS-1175, ATTACK TOOLS

The tool manifest for the dynamic and manual intervention attack tests and ascribed tool category is as follows:

TOOL CATEGORY A

- i) NON TOOL
 - 1 Soft body impactor – 30kg
- ii) PRIME KIT
 - 1 Screwdriver – 6.5mmØ/square x 150mm long
 - 1 Knife – blade 125mm long x 3mm thick
 - 1 Lever – 0.7kg/300mm long
 - 1 Glass Cutter
- iii) ADDITIONAL
 - Tweezers
 - Hooks
 - Pliers (including self gripping) – selection 200mm long
 - Spanners – selection 150mm long
 - Hexagon wrenches – selection 120mm long
 - Punches
 - Rope
 - Wire
 - Adhesive tape
 - Flexible plastic coupon
 - Wood/plastic wedges

The tools of this category are selected in order to simulate an opportunist attack by bodily physical force and by stealth using minimal tools.

TOOL CATEGORY B

Tool category A plus:

- 1 Junior hacksaw/2 HSS blades
- 1 Screwdriver – 7mmØ/square x 250mm long
- 1 Screwdriver – 14mmØ/square x 400mm long
- 1 Pipe wrench – 250mm long
- 1 Multiple slip joint pliers – 250mm long
- 1 Claw-hammer – 350mm long/0.7kg
- 1 Hand drill – 400mm long/1.5kg
- 1 HSS/HSCO or carbide drill bit – 6mm
- 1 Tube – 300mm long/38mm

This tool category provides a more determined opportunist attack by bodily physical force and tools with a higher mechanical advantage.

TOOL CATEGORY C

Tool category A and B plus:

- 1 Crowbar – 2.5kg/700mm long
- 1 Power drill (cordless with rotary action only) – 7.2V d.c.*
- 1 HSS/HSCO or carbide drill bit – 10mm (Jobber)
- 1 Hacksaw / 2HSS blades
- 1 Pad saw / 2 HSS blades
- 1 Hammer – 400mm long/1.5kg
- 1 Ax – 350mm long/1.5kg
- 1 Butane/propane gas torch
- 1 Scissor jack – 750kg capacity, 100mm minimum retracted, 200mm stroke
 - Cold chisels – 250mm long/25mm wide
 - Wood chisels – 250mm long/25mm wide
 - Brick bolster – 250mm long/75mm wide

*Each complete with a spare power pack.

The tool category is for deliberate forced entry of a well-protected premises using bodily physical force and a wide selection of attack options.

TOOL CATEGORY D

Tool category A, B and C plus:

- 1 Jigsaw (cordless) – 12V d.c.*
- 1 Disc grinder / 3 cutting discs (cordless) – 12V d.c.*
- 1 Sledge-hammer – 750mm long/3kg
- 1 Tube – 500mmØ long / 750mm
- 1 General purpose saw
- 1 Felling/fire axe – 850mm long/3kg
- 1 Power drill (cordless with rotary action only) – 12V d.c.*
- 1 Hole saw – 50mmØ
- 1 Plate shears – 300mm long
- 5 HSS/HSCO or carbide drill bits – various sizes up to 13mmØ (Jobber)
 - Bolt cutters – 500mm long
 - Steel wedges – 150mm long

*Each complete with a spare power pack.

This tool category is for experienced attempts at forced entry.

TOOL CATEGORY E

Tool category A, B, C and D plus:

- 1 Circular saw – 200mmØ/1100W
- 1 Sledge-hammer – 750mm/6kg.
- 1 Reciprocating saw – 750W
- 1 Disc grinder / 3 cutting discs – 125mm/1100W
- 1 Power drill with rotary/hammer action – 750W
- 1 Pinch bar – 1500mm long
- 5 HSS/HSCO or carbide drill bits – various sizes up to 13mmØ (Jobber and long series)
 - Wood boring spade bits
 - Hole saws>50mmØ

This tool category provides a professional means of attempting forced entry into hinge valve storage areas generally after penetrating the façade.

TOOL CATEGORY F

Tool category A, B, C, D and E plus:

- 1 Circular saw – 300mmØ/2100W
- 1 Reciprocating saw – 2000W
- 1 Disc grinder/3 cutting disc – 250mmØ/2300W
- 1 Power drill with rotary/hammer action – 2000W
- 1 Tube – 1500mm long/75mm
- 1 Saffire “Portapak” cutting blowtorch kit
- 5 HSS/HSCO or carbide drill bits – various sizes up to 20mm

This tool category is an enhancement of category E.

Note: All dimensions are maximum unless otherwise specified.

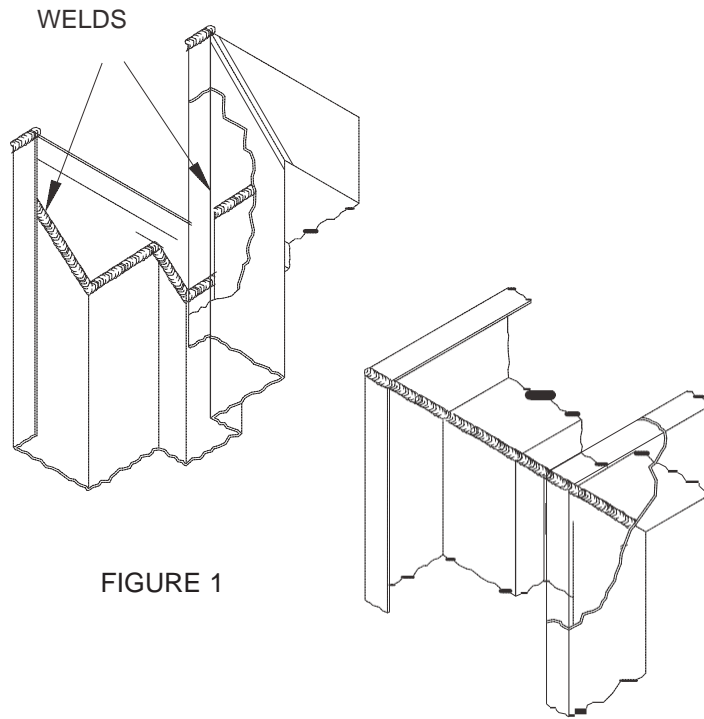

FIGURE 1

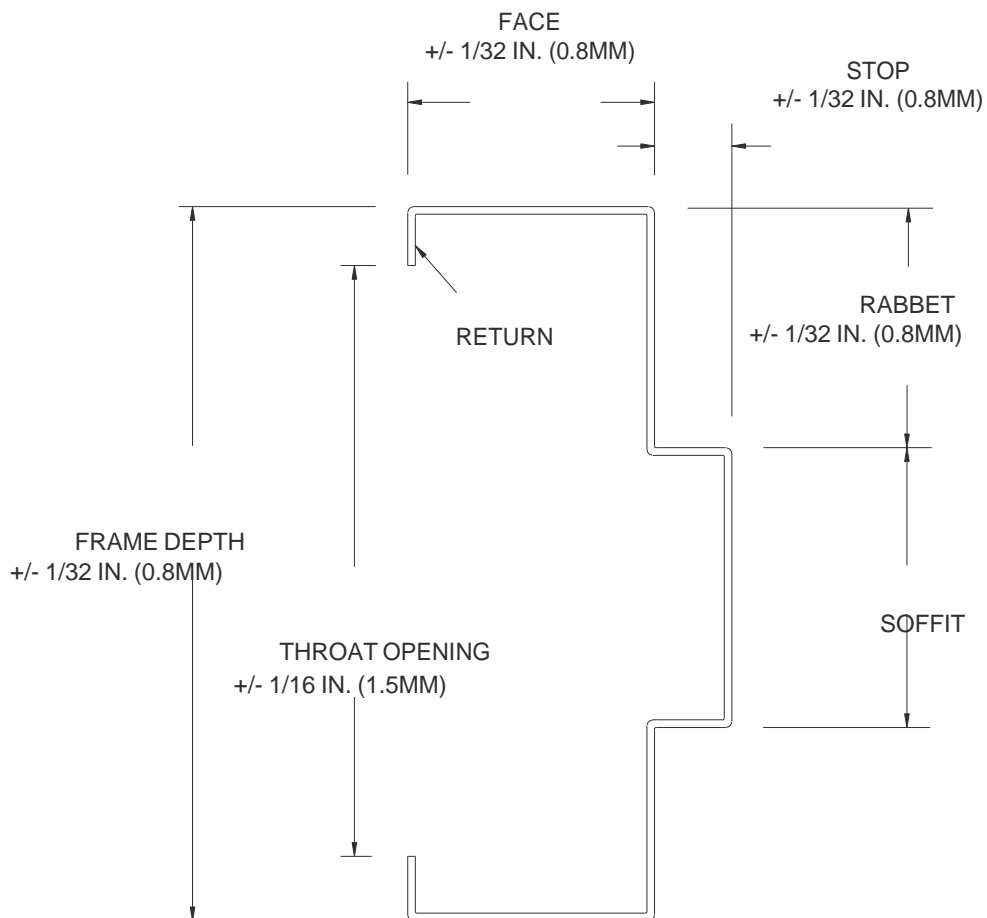
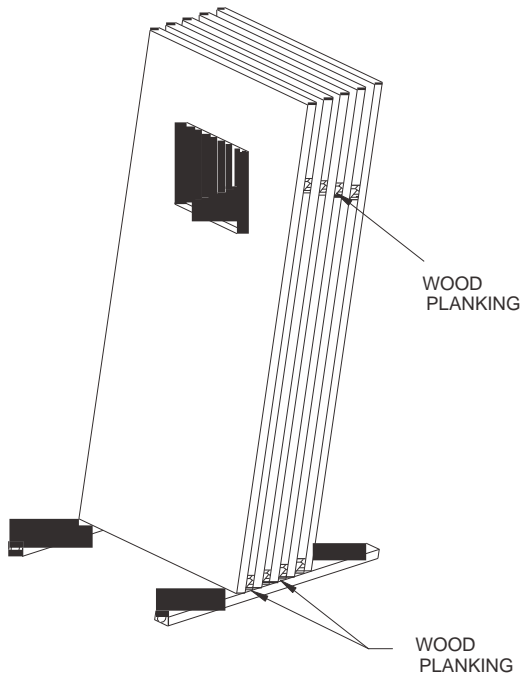

FIGURE 2



The contractor responsible for installation shall remove wraps or covers from doors and frames upon delivery at the building site. The contractor responsible for installation shall ensure that scratches or disfigurements caused in shipping or handling are promptly cleaned and touched up with a rust inhibitive primer.

The contractor responsible for installation shall ensure that materials are properly stored on planks or dunnage in a dry location. Doors shall be stored on their heads in a vertical position, to protect sound gasketing at the door bottom, and shall be spaced by blocking. Materials shall be covered to protect them from damage but in such a manner as to permit air circulation.

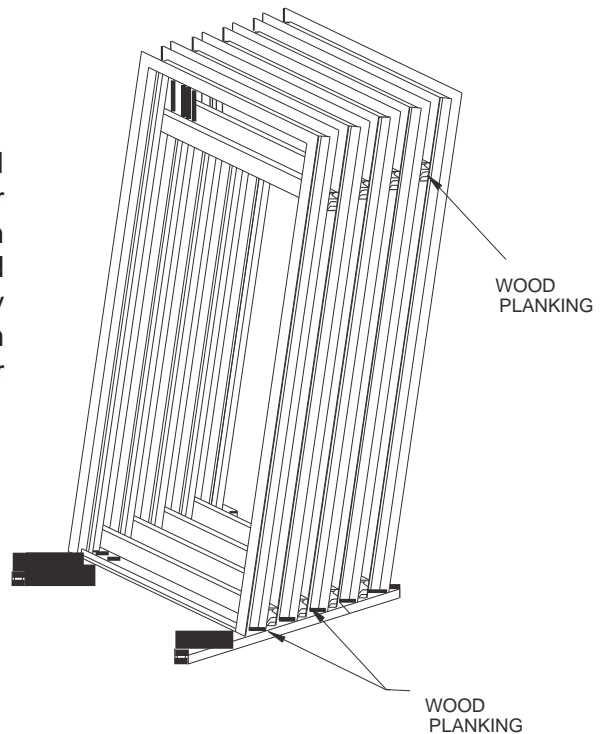

FIGURE 3
Recommended Storage

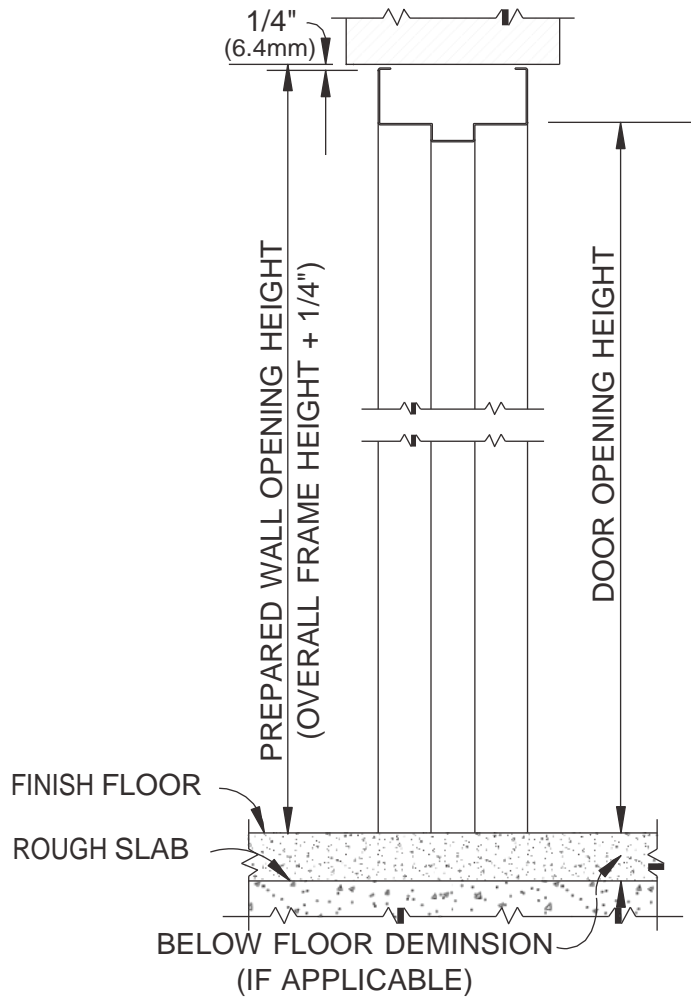

FIGURE 4

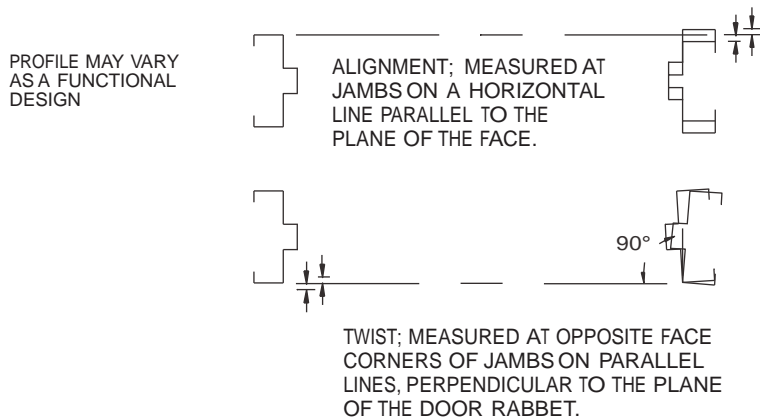
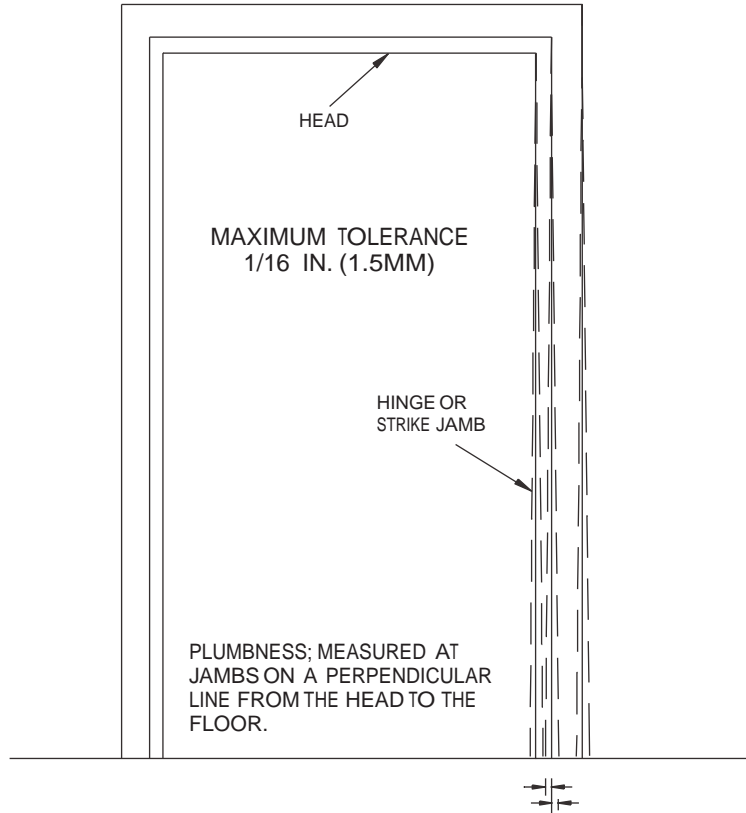
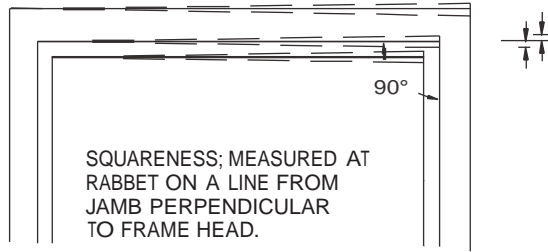

FIGURE 5
Installation Tolerances

APPENDIX

(Not part of the Standard)

NAAMM HMMA 803 STEEL TABLES

Prior to 1970, sheet steel was referred to by gage. ASTM and ANSI currently do not list gage numbers in their standards. Like many generic terms, gage (or gauge) is ingrained in many vocabularies and is misunderstood as a term for thickness. NAAMM is publishing this minimum thickness table to be used instead of discontinued gage numbers.

The values shown were taken from the Underwriters Laboratories, Inc. publication for gage number and equivalent thickness.

MINIMUM THICKNESS		
Uncoated Steel Sheet		
Gage	Decimal	mm
4	0.214	5.4
5	0.199	5.0
6	0.184	4.6
7	0.167	4.2
8	0.152	3.8
10	0.123	3.1
12	0.093	2.3
14	0.067	1.7
16	0.053	1.3
18	0.042	1.0
20	0.032	0.8
22	0.026	0.6
24	0.020	0.5
26	0.016	0.4
28	0.013	0.3

CONVERSION		
Fraction	Decimal	mm
	1.000	25.4
15/16	0.937	23.8
7/8	0.875	22.2
13/16	0.812	20.6
3/4	0.750	19.0
11/16	0.687	17.4
5/8	0.625	15.8
9/16	0.562	14.2
1/2	0.500	12.7
7/16	0.437	11.1
3/8	0.375	9.5
5/16	0.312	7.9
1/4	0.250	6.3
3/16	0.187	4.7
1/8	0.125	3.1
1/16	0.062	1.5

DISCLAIMER

This sheet was developed by representative members of the Hollow Metal Manufacturers Association Division (HMMA) of the National Association of Architectural Metal Manufacturers (NAAMM) to provide their opinion and guidance on minimum thickness and metric equivalents used for hollow metal doors and frames. This sheet contains advisory information only and is published as a public service by the HMMA Division. NAAMM and its HMMA DIVISION DISCLAIM ALL LIABILITY OF ANY KIND FOR THE USE, APPLICATION OR ADAPTATION OF MATERIAL SHOWN ON THIS SHEET,

HMMA Hollow Metal Manufacturers Division of the
National Association of Architectural Metal Manufacturers **NAAMM**

RECOMMENDED GUIDE SPECIFICATIONS FOR HMMA HOLLOW METAL DOORS AND FRAMES

HMMA 860 — Hollow Metal Door and Frames

ANSI/NAAMM

HMMA 861 — FE/BR Hollow Metal Doors and Frames

ANSI/NAAMM

HMMA 862 — FE/BR Security Hollow Metal Doors and Frames

ANSI/NAAMM

HMMA 863 — Detention Security Hollow Metal Doors and Frames

ANSI/NAAMM

HMMA 865 — Swinging Sound Control Hollow Metal Doors and Frames

ANSI/NAAMM

HMMA 866 — Stainless Steel Hollow Metal Doors and Frames

ANSI/NAAMM

HMMA 867 — FE/BR Laminated Core Hollow Metal Doors and Frames

RELATED HMMA DOCUMENTS

HMMA 800 — Introduction to Hollow Metal

HMMA 801 — Glossary of Terms for Hollow Metal Doors and Frames

HMMA 802 — Manufacturing of Hollow Metal Doors and Frames

HMMA 803 — Steel Tables

HMMA 805 — Recommended Selection and Usage Guide for Hollow Metal Doors and Frames

HMMA 810 — Hollow Metal Doors

HMMA 820 — Hollow Metal Frames

HMMA 830 — Hardware Selection for Hollow Metal Doors and Frames

HMMA 831 — Recommended Hardware Locations for Hollow Metal Doors and Frames

HMMA 840 — Installation and Storage of Hollow Metal Doors and Frames

HMMA 841 — Tolerances and Clearances for FE/BR Hollow Metal Doors and Frames

HMMA 850 — Fire-Rated Hollow Metal Doors and Frames

HMMA 890 — Technical Summary

HMMA 810-TN01 — Defining Undercuts

HMMA 820-TN01 — Grouting Hollow Metal Frames

HMMA 820-TN02 — Continuously Welded Frames

HMMA 820-TN03 — Guidelines for Glazing Hollow Metal Transoms, Sidelights and Windows

HMMA 840-TN01 — Painting Hollow Metal Products

HMMA 840-TN02 — Maintenance of Installed Hollow Metal Products